

KONE MiniSpace™ DX



The
connected,
high-speed
elevator
is here



A new era of elevator experience

In an increasingly digitalised world, everything is connected, and elevators are no exception. With the KONE MiniSpace™ DX you can create a completely new kind of elevator experience in mid and high-rise buildings.

DX stands for digital experience, because with the KONE MiniSpace DX you can create an experience that really connects, on every level. Connectivity lets you benefit from improved people flow plus a variety of innovative new services to make everyday life even easier and more enjoyable.

Powered by the compact, energy-efficient KONE EcoDisc® hoisting motor, the KONE MiniSpace DX features a highly compact machine room that is simply an extension of the elevator shaft – meaning it's fast and cost-efficient to install. Contact your local KONE sales representative to find out more.

We help you accelerate construction and lower construction costs with productivity enhancing construction time use solutions that help building projects finish ahead of schedule. Contact your local KONE sales representative to find out more.

Key specifications

API ready

Connected

Max. load capacity 2,000 kg

Max. speed 4.0 m/s

A-Class energy efficient ISO 25745 rating

Max. travel 210 m

Max. floors 63

Max. persons 26

Max. group size 8

Regenerative drive technology

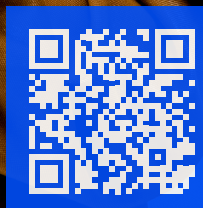



1

Get more value out of every square metre with connectivity

By adding connectivity to your elevators you make them smarter and more desirable – helping you get more value out of every square metre of your building. New services enabled by the KONE digital platform and KONE Partner Ecosystem, as well as application programming interfaces (APIs), make everyday life even easier and more convenient for everyone.

2

Accelerate construction with improved productivity

With our new improved construction time solutions and processes, we can optimise your productivity and accelerate the completion of your building projects by several weeks or even months. We make people and material flows on-site as fast and efficient as possible.

3

Differentiate with a redefined user experience for tenants and visitors

Redefine the elevator user experience, bring your vision to life, and inspire users with our new car interior designs, functional and durable materials, direct and indirect lighting, infotainment features, and user-friendly signalisation.

4

Partner for smart and sustainable buildings

Make the right decisions first time and plan your elevator down to the very last detail with our next-generation planning tools. We also offer sustainable materials and technologies to help you achieve green building certifications and ensure compliance with safety codes and standards.

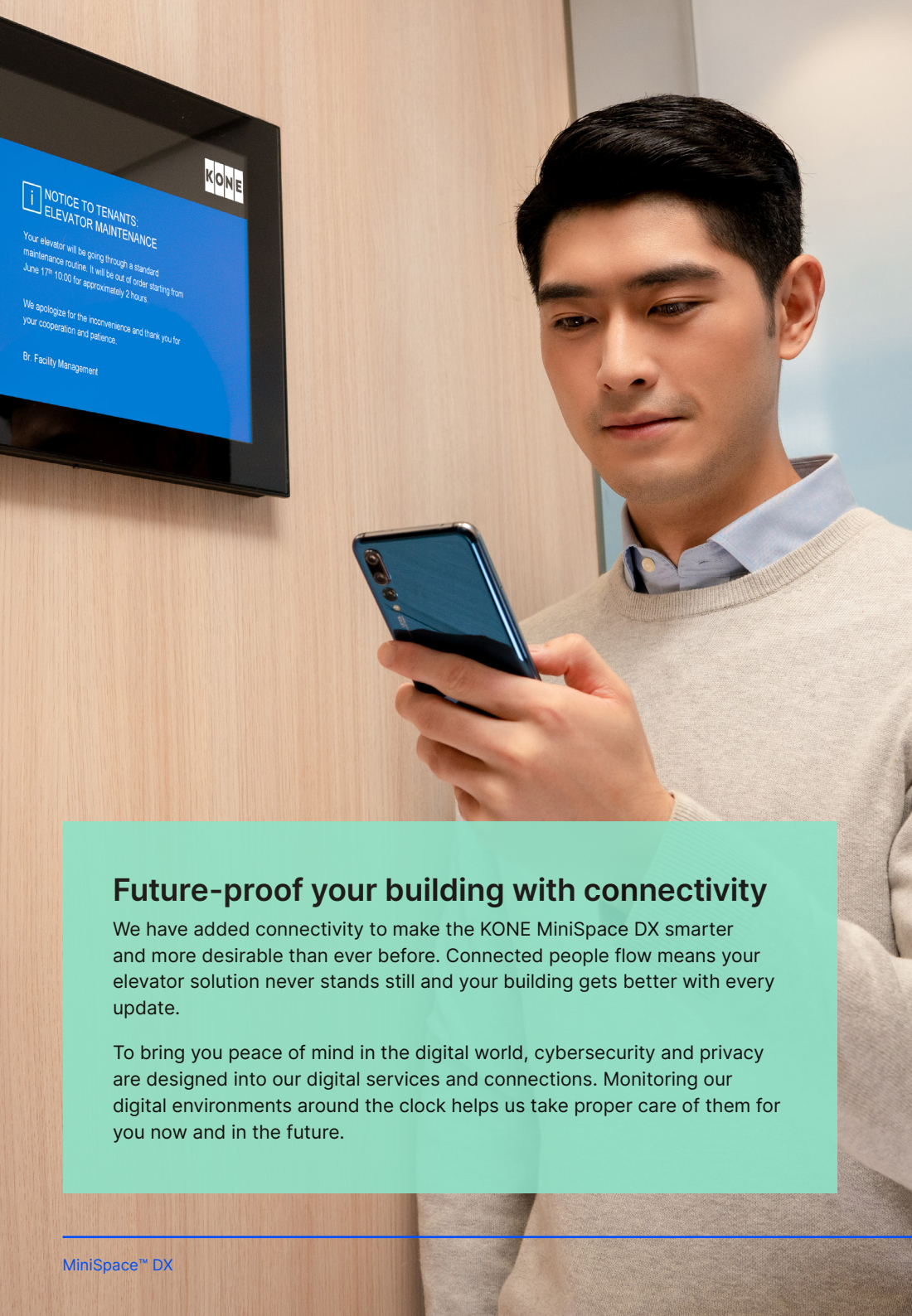

Easy to upgrade

Connectivity gives you the possibility to upgrade in the future as your needs change by adding new connected services and features as and when you need them.

Best-in-class energy efficiency

Save energy and cut your building's carbon footprint with our eco-efficient hoisting, high-efficiency regenerative drive, long-lasting LED lighting, and energy-saving standby operation.

Less space, faster construction

The machine room is simply an extension of the elevator shaft, making installation safer, faster, and more cost-efficient.

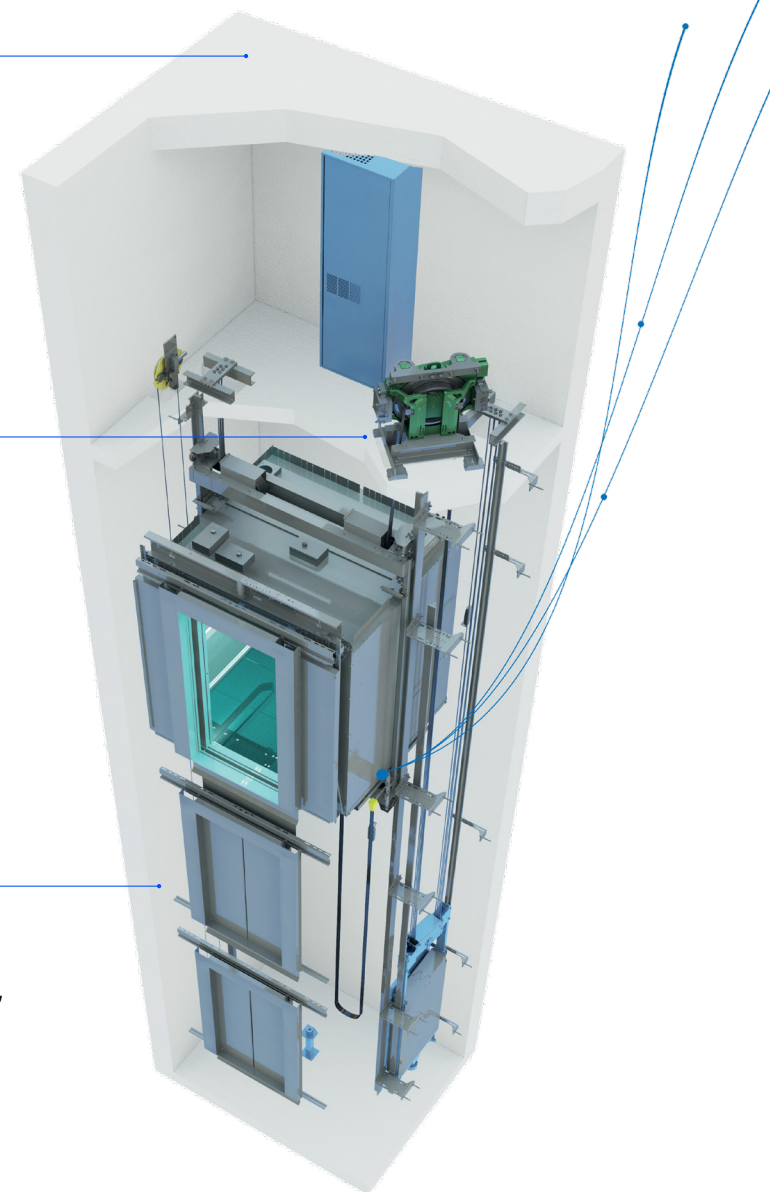

Future-proof your building with connectivity

We have added connectivity to make the KONE MiniSpace DX smarter and more desirable than ever before. Connected people flow means your elevator solution never stands still and your building gets better with every update.

To bring you peace of mind in the digital world, cybersecurity and privacy are designed into our digital services and connections. Monitoring our digital environments around the clock helps us take proper care of them for you now and in the future.

Get more value out of every square metre with connectivity

Smart solutions based on connected digital technologies not only help buildings attract a premium price, they also help to speed up the sales or leasing process.

With KONE MiniSpace DX you can take advantage of a whole new suite of solutions and services that make life easier and more convenient for users. These include digitally enabled KONE solutions like KONE Residential Flow for improved accessibility and people flow, and KONE 24/7 Connected Services for the best possible elevator availability.

With KONE APIs you also have the freedom to develop your own smart building solutions, allowing you to further customise the elevator experience to meet the needs of your building and its users.

You can also benefit from solutions and services developed by the growing number of partners of the KONE Partner Ecosystem, which develops solutions that can be integrated with KONE DX Class elevators.

Improve convenience and comfort

KONE 24/7 Connected Services provides elevator status data for easier monitoring and troubleshooting. It increases safety and provides full transparency and peace of mind, because if something would happen, we'd already know about it.



Accelerate construction with improved productivity

Our solutions help to maximise elevator uptime and move construction site workers and material around the building more efficiently during the construction process to help you finish your project sooner.

KONE construction time use elevators

The final elevators are equipped with protective materials so they can be used during construction.

KONE JumpLift

A self-climbing construction time elevator solution uses the building's permanent elevator shaft during construction for smooth logistics that speed up building completion and lead to a quicker return on investment.

Plan for success with KONE as your partner

Your journey with KONE is a simple one. In a complex project, the pressure to stay on schedule and within plan is high. Our people and partners, from technicians to project managers, are fully committed to the highest customer satisfaction in the industry.

That is why we have the best processes and tools to support you every step of the way.

Professional project management

When you buy a solution from KONE, you're getting far more than just equipment and installation. Every single project we handle is led by a dedicated, accredited project manager with solid experience of running similar projects.

Building Information Modelling (BIM)

We use digital planning techniques like BIM to prepare for the installation process. This helps you understand and optimise your construction project.

Site readiness

To make sure everything we need is in place before we begin installation, we can monitor and report the readiness state of the site.

Efficient installation

The KONE elevator installation process doesn't require scaffolding, which cuts costs and minimises disruption to other construction work on site.

Quality assurance and maintenance

Before your elevator is handed over, we take every necessary measure to ensure that you're taking delivery of a high-quality solution that will run as it should from day one.



Differentiate With A Redefined User Experience For Tenants And Visitors

Deliver a user experience that inspires, informs, and delights. With KONE MiniSpace DX Class elevators you can harness the power of digitalisation to take the elevator journey far beyond the ordinary. A whole new range of car designs, material options, and lighting and signalisation choices – as well as customisable digital infotainment solutions and health and well-being solutions – adds value to your building.



Functional, durable materials

Design a car interior that's easier than ever to clean, maintain, and keep looking its best with our new range of innovative materials, including finishes with anti-fingerprint properties.*



Human insight-driven design

Create just the right ambience with new elevator lighting designs. Our new range includes direct and indirect lighting that can be combined to stunning effect.



Health and well-being solutions

KONE's people flow expertise, together with a range of health and well-being solutions, help to increase safety and contribute to a healthier building environment.

*Anti-stain, anti-fingerprint coating: This specialised coating helps keep coloured stainless steel elevator materials looking as good as new by preventing staining and making fingerprints less visible.

Plan for success with KONE as your partner

Now more than ever, it's vital we work together to build smart, sustainable, and adaptable buildings that last. Build greener and make sure your project is on track to meet industry codes and standards with our next-generation planning tools, safe and sustainable materials, and expert support.

Build greener

KONE solutions and expertise can make all the difference when you're aiming to achieve green building certifications and credits for schemes like BREEAM, LEED, and Green Mark.

Build to standards

The KONE MiniSpace DX complies with all relevant industry codes and standards. Talk to your local KONE sales representative about how we can support you with issues such as accessibility, vandal-resistance, and fire code compliance.

Build with a partner

You benefit from comprehensive support throughout your building's lifecycle, from expert planning advice to flexible maintenance and modernisation solutions and services.



Design your elevator

With our digital design tool you can create your own unique elevator car interior by combining materials, lighting, and accessories – and then bring your vision to life with 3D modelling.



AUSTRALIA	www.kone.com.au
ACT	
Canberra and South West	+61 2 6123 2600
NSW	
Sydney	+61 2 9577 7000
Newcastle and North Coast	+61 2 4949 3333
QLD	
Brisbane	+61 7 3270 1811
Cairns	+61 7 3270 1810
Gold Coast	+61 7 3270 1810
Sunshine Coast	+61 7 3270 1810
Townsville	+61 7 3270 1810
NT	
Darwin	+61 7 3270 1810
WA	
Perth	+61 8 9270 9000
SA	
Adelaide	+61 8 8130 3800
TAS	
Hobart	+61 3 6231 2045
VIC	
Melbourne	+61 3 9934 8000

NEW ZEALAND	www.kone.co.nz
NTH	
Auckland	+64 9 361 9000
Wellington	+64 4 381 4330
STH	
Christchurch	+64 3 338 3900
Dunedin	+64 3 477 5627

Want to know more?
Contact your KONE
representative today!
www.kone.com.au
www.kone.co.nz

This publication is for general informational purposes only and we reserve the right at any time to alter the product design and specifications. No statement this publication contains shall be construed as a warranty or condition, express or implied, as to any product, its fitness for any particular purpose, merchantability, quality or representation of the terms of any purchase agreement. Minor differences between printed and actual colours may exist. KONE MonoSpace® DX, KONE EcoDisc®, KONE Care® and People Flow® are registered trademarks of KONE Corporation. Copyright © 2024 KONE Corporation